

**GETAWAY MARKETING, INC.
REPRESENTING
GLAVAL BUS**



NOW! Ford Chassis and Hybrid Option Available

ORDER PACKET

**Contract #FVPP-08-SC-GM
Small Cutaway Type Vehicles**

CONTRACT # FVPP-08-SC-GM

**ORDER PACKET GLAVAL SMALL CUTAWAYS
ON CHEVROLET GMC 610 3500 CHASSIS; FORD E-350; FORD E-450;
and AZURE ELECTRIC HYBRID OPTION**

GETAWAY MARKETING, INC.

General Information

The Florida Vehicle Procurement Program (FVPP) issued Proposal #FVPP-08-SC-GM to establish a series of state contracts for the purchase of Body on Chassis Cutaway Type Vehicles. Through this process four contracts were awarded to two different vendors each representing a different vehicle manufacturer.

This Order Packet is for Contract #FVPP-08-SC-GM, which was awarded to Getaway Marketing, Inc. on February 11, 2008, to provide Glaval Bus Small Cutaway Type Vehicles in length of 21' 0" on Chevrolet/GMC 610 CC3500 chassis with a Gross Vehicle Weight Rating (GVWR) of 12,300 pounds.

This Order Packet contains the necessary instructions and forms for agencies to place an order with Getaway Marketing, Inc. to purchase these vehicles. This Order Packet also provides guidance and clarity on the relationships between the seller, the buyer, and Florida DOT's FVPP.

The complete Contract #FVPP-08-SC-GM is accessible from the FVPP website <http://www.cutr.usf.edu/fvpp> and contains the following sections:

- **Part 1** - General Requirements and Conditions, and Contractual Provisions
(Including copies of all U.S. DOT Federal Transit Administration certifications)
- **Part 2** - Technical Specifications
- **Part 3** - Options
- **Part 4** - Quality Assurance Provisions
- **Part 5** - Warranty Provisions
- **Part 6** - Paint Schemes

For further information on the FVPP and Contract #FVPP-08-SC-GM, please contact either Hank Cusack (813-974-7834) or Cindy Wooten (813-974-9771) at the University of South Florida, Center for Urban Transportation Research (CUTR).

Vendor Information

To place an order for a vehicle under Contract #FVPP-08-SC-GM, contact Susan Gould at Getaway Marketing, Inc.:

- **Address:** Getaway Marketing, Inc.
4933 17th Street East
Bradenton, Florida 34203
- **Telephone #:** (877) 287-7287
- **Fax #:** (904) 241-0507
- **Email:** www.getawaybus.com
- **Contact Person:** Susan Gould, President

Procedures for Ordering

The following sections provide guidance to be used by the vendor and the agencies in the ordering, delivery, acceptance and payment for vehicles procured under this contract. All parties are advised to fully review the full contract document available on the FVPP website. Contract #FVPP-08-SC-GM will be the governing document.

Agencies should understand that each order placed with and acknowledged by Getaway Marketing, Inc. constitutes a contract between the purchaser and Getaway Marketing, Inc. only. The contract implies no duties or responsibilities by the University of South Florida, Center for Urban Transportation Research or the Florida Department of Transportation. The terms and conditions of this contract are to be administered and enforced by and between the agency and the vendor.

ORDERING INSTRUCTIONS

Agencies must utilize the order forms in this Order Packet to place their orders. Agencies are encouraged to contact and work closely with Getaway Marketing, Inc. in finalizing their orders, to fully understand the options available, to select the floor plans and seating selections, the paint schemes, and any special options or conditions that may impact the final order and purchase price. Please submit a separate order form for each vehicle ordered.

Contract #FVPP-08-SC-GM is to provide Glaval Bus Small Cutaway Type Vehicles in length of 21 feet on Chevrolet/GMC 610 CC3500 chassis with a Gross Vehicle Weight Rating (GVWR) of 12,300 pounds. Among the standard components of this vehicle are:

- Chevrolet/GMC 610 CC3500 Chassis
- Chevy 6.0L V-8 SFI Vortec gasoline engine, 300 HP @ 4400 RPM
- Heavy duty 4-speed with overdrive transmission
- Fire Suppression system

- Multiplex electrical system
- Electric door operation
- Multiple floor layouts and seating options
- Choice of wheelchair lift types and models and securement system
- Optional stretcher securement system
- Several standard paint schemes, including reflective material and wraps
- Several other options

Most agencies already have an idea on the type and number of seats and wheelchair positions needed to meet their floor plan requirements. A wide variety of floor plans are available. Agencies should work closely with Getaway Marketing, Inc. to develop and finalize their floor layout plans. Based upon this consultation, Getaway Marketing, Inc. will develop a proposed floor plan based on the Agency's needs and fax a copy of the plan to the Agency for verification and approval.

The Order Packet also includes illustrations of the basic vehicle paint schemes and the description of the available options to assist the Agency in completing your orders.

Included in this Order Packet are the following forms and information:

- Order Form that provides:
 - Base vehicle prices
 - Unit seating and wheelchair station prices
 - Paint scheme options and prices
 - Individual option and prices
 - Sample choice forms
- Sample Order Form – providing an example as how to complete the order form
- Description of Options
- Available Paint Schemes

Please submit a separate order form for each vehicle ordered. After determining the length of bus, floor plan, paint scheme and desired individual options, to complete the order form place the number of items in the corresponding quantity column. Multiply the dollar figure in the cost column by the number of items in the quantity column to calculate a total cost for that item. Enter that amount in the total cost column. Add the total cost column amounts together to arrive at the grand total for the vehicle. The grand total will be the figure used on the Agency's purchase order.

Unless your vehicle is funded in part by the FTA Section 5310 grant program, the Agency deals directly with Getaway Marketing, Inc.

Once the details of the order are finalized, an Agency Purchase Order payable to Glaval Bus, A Division of Forest River, Inc. must accompany all orders placed with Getaway Marketing, Inc. for those vehicles not funded by the FTA Section 5310 grant program.

For all vehicles funded through the FTA Section 5310 grant program, a copy of the completed order form and either an Agency purchase order or a check for the Agency's portion payable to Glaval Bus, A Division of Forest River, Inc. must be mailed or faxed to the CUTR Section 5310 Program Coordinator:

Ms. Cindy Wooten
FVPP Section 5310 Program Coordinator
USF-CUTR
4202 E. Fowler Avenue – CUT100
Tampa, Florida 33620
Telephone: (813) 974-9771
Fax: (813) 396-9345
Email: wooten@cutr.usf.edu

The FVPP Section 5310 Program Coordinator will verify the order accuracy, complete the request for the FDOT share, and forward the request to Tallahassee for the FDOT purchase order. When the FDOT purchase order number is assigned, the FVPP Section 5310 Program Coordinator will place the order with Getaway Marketing, Inc. and notify the Agency of its status.

Getaway Marketing, Inc. will provide written confirmation to the Agency and/or CUTR of the receipt of the order within seventy-two (72) hours of receiving the order with purchase order. At a minimum, the acknowledgement of the order will contain:

- The Agency's purchase order number
- The date the order was received
- The date the order was placed with the manufacturer
- The production and VIN number when available
- The estimated delivery date (when available)

DELIVERY

Completed units must be delivered to Agency within ninety (90) days from receipt of chassis or purchase order, whichever occurs last.

In the event of delay in completion of the delivery of vehicles beyond the date specified in the contract, in addition to any granted extensions agreed to in writing by the Agency, the Agency may assess as liquidated damages, twenty five dollars (\$25.00) per calendar day per vehicle.

Each vehicle purchased through the FVPP shall be routed to the FDOT's Springhill Inspection Facility, located in Tallahassee, Florida, for an inspection prior to delivery to Getaway Marketing, Inc.

Getaway Marketing, Inc. should see that all noted write-ups are corrected prior to final delivery to the procuring agency. This inspection by the FVPP is not represented as being

"all inclusive" and in no way relieves the dealer from the required Pre-Delivery Inspection (PDI).

Prior to the vehicle(s) being delivered, Getaway Marketing, Inc. must perform a PDI. Upon completion of a PDI, Getaway Marketing, Inc. will be required to deliver the vehicles to the Purchaser. The dealer shall notify both the purchasing Agency and the FDOT District Office a minimum of 48 hours in advance to arrange a delivery time.

The vehicle shall be delivered with all Contractor/manufacturer's quality control checklists including road test and final inspection (properly completed and signed by an authorized plant representative). Other documents/items required at delivery include:

- Manufacturer's Certificate of Origin
- Application for Certificate of Title
- Bill of Sale
- Warranty Papers (forms, policy, procedures)
- Maintenance Schedule
- Operators' manual
- Invoice (To include contract number, P.O. number, VIN#, and agency name)

FINAL ACCEPTANCE

Delivery of the vehicle(s) by Getaway Marketing, Inc. does not constitute acceptance by the Agency. The vehicle will be considered "accepted" upon passing the inspection and issuance of an acceptance letter by the Agency.

The terms of the contract state that an Agency has ten (10) calendar days after receiving the vehicle(s) to perform the Post Delivery Inspection and issue either a "Letter of Acceptance" or a "Letter of Rejection" to Getaway Marketing, Inc. and the Florida DOT District Office contact. The "Letter of Rejection" will state and describe the areas to be found in noncompliance with the bid specifications, incompleteness, or any defective or damaged parts.

A vehicle should be rejected if any items are missing, defective, altered, incorrect, or incomplete. In the event a vehicle(s) is delivered incomplete or contains any defective or damaged parts, the said parts will be removed and replaced by Getaway Marketing, Inc. New parts will be furnished and installed by Getaway Marketing, Inc. at no cost to the Agency. If there is work involved, warranty or otherwise, to repair or place the vehicle(s) in proper complete condition, such repairs will be made by an approved firm in accordance to the warranty provisions of the contract.

Placing the vehicle(s) in revenue service will automatically constitute "acceptance". In such circumstances, a "Letter of Acceptance" should still be sent to Getaway Marketing, Inc. Acceptance of the vehicles shall not release the Contractor from liability for faulty workmanship or materials.

PAYMENT

For vehicle purchased without funding from the FTA Section 5310 grant program, the Agency should complete all necessary paperwork and submit its request to process the Agency purchase order payment to Glaval Bus, A Division of Forest River, Inc. within five (5) days after the delivery and/or acceptance of the vehicle.

The remittance information is: Glaval Bus, A Division of Forest River, Inc.
Attn: Bert Borkholder
914 County Road 1
Elkhart, IN 46514

For all vehicles funded through the FTA Section 5310 grant program, the Agency should approve and process its purchase order to allow a check for the Agency amount to be sent to Glaval Bus, A Division of Forest River, Inc. for its share of the vehicle. If, instead of a purchase order, a check was provided at the order request time, forward all invoices to the CUTR Section 5310 Program Coordinator along with the acceptance letter.

Upon receipt of the Agency's portion of the vehicle, Getaway Marketing, Inc. will contact the CUTR Section 5310 Program Coordinator with a request to process the FDOT purchase order payment approval.

The remittance information is: Glaval Bus, A Division of Forest River, Inc.
Attn: Bert Borkholder
914 County Road 1
Elkhart, IN 46514

The total purchase price should be paid in full within sixty (60) days after acceptance of each vehicle. Agencies should note that failure to meet the net 60-day payment terms could result in the assessment of interest and other penalties. Terms are those shown in Price Proposal Form F of the contract document. A 2% monthly service charge will be added to all past due accounts.

EXHIBIT A

ORDER FORM

ORDER FORM – PAGE ONE

CONTRACT # FVPP-08-SC-GM
ORDER PACKET GLAVAL SMALL CUTAWAYS

GETAWAY MARKETING, INC.

AGENCY NAME: _____ **DATE:** _____

PURCHASE ORDER NUMBER: _____

CONTACT PERSON: _____

(Name, Telephone Number and Email Address)

December 2009

Item	Unit Cost	Quantity	Total Cost
Base Vehicle Type			
Chevrolet/GMC CC3500 22' 3" 12,300 GVWR	\$56,571		
Ford E-350 22' 3" 11,700 GVWR	\$54,871.		
Ford E-450 22 Foot 14,500 GVWR 6.8L Std. Gas Only	\$60,962		
Ford E-450 Hybrid 22 Foot 14,050 GVWR Std Gas Only	\$108,113		
Paint Scheme Choices			
Scheme #1	\$650		
Scheme #2	\$425		
Scheme #3	\$365		
Floor Plan Choices			
Freedman Standard Seat <i>(per person)</i>	\$250		
Flip-up Seat <i>(per person)</i>	\$295		
Foldaway Seat <i>(per person)</i>	\$350		
Children's Seat <i>(per person)</i>	\$315		
Securement Systems			
Q'Straint QRTMAX securement <i>(per position)</i>	\$485		
Sure-Lok securement <i>(per position)</i>	\$485		
Seat belt extensions <i>(2-sets standard)</i>	\$18		
Stretcher securement system storage included	\$750		
Side Wheelchair Lift Choices <i>(pick one)</i>			
Braun	\$2,955		
Maxon	\$2,955		
Ricon	\$3,310		
PAGE ONE SUB-TOTAL	----	----	

ORDER FORM – PAGE TWO

Item	Unit Cost	Quantity	Total Cost
PAGE TWO SUB-TOTAL <i>(sub-total of second page)</i>	----	----	
PAGE ONE SUB-TOTAL <i>(carry forward from previous page)</i>	----	----	
GRAND TOTAL <i>(sum of page 1 and 2 sub-totals)</i>	----	----	

CHOICES FORM

**CONTRACT # FVPP-08-SC-GM
GLAVAL SMALL CUTAWAYS**

GETAWAY MARKETING, INC.

SEATING AND FLOORING CHOICES

Seating Colors: (circle one) Blue Gray Beige

Flooring Colors: (circle one) Blue Gray Beige Black

Paint Scheme: (circle one) #1 #2 #3 Other

Paint Schemes Note: Agencies will select colors (2) for background and stripes when orders are placed. All paint, or reflective material scheme pricing, shall reflect white base coat. If an agency requires a paint and lettering scheme that is NOT GENERALLY covered by one of those listed above, they may make separate arrangements either with the manufacturer or a local vendor to provide these services.

Upholstery Information-Vinyl Colors Available:

Blue Vinyl Combo: Center insert of seat to be Blue/Gray Print CMI part # VP-MEDLI-KEAZU, Outside wrap and back of seat to be Blue solid CMI part # VP-MEDLI-TRAZU.

Gray Vinyl Combo: Center insert of seat to be Blue/Gray Print CMI part # VP-MEDLI-KEAZU, Outside wrap and back of seat to be Gray solid CMI part # VP-MEDLI-TRGRY.

Beige Vinyl Combo: Center insert of seat to be Beige Print CMI part # VP-MEDLI-KEVER, Outside wrap and back of seat to be Beige solid CMI part # VP-MEDLI-DOSNB.

WHEELCHAIR LIFT CHOICE

Wheelchair Lift: (circle one) Braun
Ricon
Maxon

SECUREMENT RETRACTOR CHOICE

W/C Securement: (circle one) Q'Straint QRTMAX Sure-Lok

EVENT DATA RECORDER CHANNEL SYSTEMS SELECTION

As detailed in Section 2.45 of the Technical Specifications, an event data recorder (EDR), Circuitlink International “Tacholink”, (or approved equal) will be mounted on each vehicle.

The EDR will provide a continuous log of vehicle activity. Speed history, odometer, excessive RPM, heavy braking, fast acceleration, and idling exceptions will automatically be recorded by exception. In the event of an accident, all data shall be permanently captured in “tamperproof” flash memory (4MB minimum) for a minimum of (30) seconds prior to the incident and (15) seconds after the incident at a minimum interval of 25 milliseconds.

The EDR will provide an automatic trigger function with different user definable thresholds for moving and stationary conditions. A manual driver alert button will be provided to allow driver “tagging” of either an accident or vehicle fault condition shall be located behind upper bulkhead and must be accessible through a latching door.

All software for user configuration, data logging, and downloading and report generation will be included. All software will be Windows-based. Trip data will be stored in Microsoft Access database. All data will be the property of Florida DOT and will be immediately available to Florida DOT. There will be no additional charges, for hardware and/or software services or annual fees will be incurred by Florida DOT or any operator.

Additional digital input channels will be provided to allow for status monitoring of a maximum of eight (8) vehicle sub-systems. Standard systems that will be monitored shall be: brakes, lights, signals, flashers, driver’s seat belt, wheelchair lift, engine temperature and front door. Each agency may substitute any of the standard systems detailed above with any of the following optional systems: oil pressure, low air pressure, low voltage, or emergency exit door. The limit of the total systems to be monitored is eight (8).

Below, please indicate the eight (8) vehicle sub-systems to be monitored on this vehicle. If no selection made, the standard systems will be programmed. For each of the optional systems you select, you must not include one of the standard system selections. A limit of eight (8) total systems per bus can be monitored.

Select Eight Systems To Be Monitored (Maximum of Eight (8))			
STANDARD SYSTEMS		OPTIONAL SYSTEMS	
	1. Brakes		9. Oil Pressure
	2. Lights		10. Low Air Pressure
	3. Signals		11. Low Voltage
	4. Flashers		12. Emergency Door Exit
	5. Driver’s Seat Belt		
	6. Wheelchair Lift		
	7. Engine Temperature		
	8. Front Door		

EXHIBIT B

SAMPLE ORDER FORM

SAMPLE ORDER FORM – PAGE ONE

CONTRACT # FVPP-08-SC-GM
ORDER FORM FOR GLAVAL SMALL CUTAWAYS

GETAWAY MARKETING, INC.

AGENCY NAME: _____

DATE: _____

PURCHASE ORDER NUMBER: _____

CONTACT PERSON: _____

(Name, Telephone Number and Email Address)

December 2009

Item	Unit Cost	Quantity	Total Cost
Base Vehicle Type			
Chevrolet/GMC CC3500 22' 3" 12,300 GVWR	\$56,571	1	\$56,571
Ford E-350 22' 3" 11,700 GVWR	\$54,871		
Ford E-450 22 Foot 14,500 GVWR 6.8L Std. Gas Only	\$58,412		
Ford E-450 Hybrid 22 Foot 14,050 GVWR Std Gas Only	\$105,563		
Paint Scheme Choices			
Scheme #1	\$650		
Scheme #2	\$425	1	\$425
Scheme #3	\$365		
Floor Plan Choices			
Standard Seat <i>(per person)</i>	\$250	6	\$1,500
Flip-up Seat <i>(per person)</i>	\$295		
Foldaway Seat <i>(per person)</i>	\$350	2	\$700
Children's Seat <i>(per person)</i>	\$315		
Securement Systems			
Q'Straint QRTMAX securement <i>(per position)</i>	\$485		
Sure-Lok securement <i>(per position)</i>	\$485	2	\$970
Seat belt extensions <i>(2-sets standard)</i>	\$18	1	\$18
Stretcher securement system storage included	\$750		
Side Wheelchair Lift Choices <i>(pick one)</i>			
Braun	\$2,955	1	\$2,955
Maxon	\$2,955		
Ricon	\$3,310		
PAGE ONE SUB-TOTAL	----	----	\$63,139

Item	Unit Cost	Quantity	Total Cost
<p>PAGE TWO SUB-TOTAL <i>(sub-total of second page)</i></p>	----	----	\$8,841
<p>PAGE ONE SUB-TOTAL <i>(carry forward from previous page)</i></p>	----	----	\$63,139
<p>GRAND TOTAL <i>(sum of page 1 and 2 sub-totals)</i></p>	----	----	\$71,980

SAMPLE CHOICES FORM

CONTRACT # FVPP-08-SC-GM
ORDER FORM FOR GLAVAL SMALL CUTAWAYS

GETAWAY MARKETING, INC.

SEATING AND FLOORING CHOICES

Seating Colors: (circle one) Blue Gray Beige

Flooring Colors: (circle one) Blue Gray Beige Black

Paint Scheme: (circle one) #1 #2 #3 #4 Other

Paint Schemes Note: Agencies will select colors (2) for background and stripes when orders are placed. All paint, or reflective material scheme pricing, shall reflect white base coat. If an agency requires a paint and lettering scheme that is NOT GENERALLY covered by one of those listed above, they may make separate arrangements either with the manufacturer or a local vendor to provide these services.

Upholstery Information-Vinyl Colors Available:

Blue Vinyl Combo: Center insert of seat to be Blue/Gray Print CMI part # VP-MEDLI-KEAZU, Outside wrap and back of seat to be Blue solid CMI part # VP-MEDLI-TRAZU.

Gray Vinyl Combo: Center insert of seat to be Blue/Gray Print CMI part # VP-MEDLI-KEAZU, Outside wrap and back of seat to be Gray solid CMI part # VP-MEDLI-TRGRY.

Beige Vinyl Combo: Center insert of seat to be Beige Print CMI part # VP-MEDLI-KEVER, Outside wrap and back of seat to be Beige solid CMI part # VP-MEDLI-DOSNB.

WHEELCHAIR LIFT CHOICE

Wheelchair Lift:(circle one) Braun Ricon Maxon

SECUREMENT RETRACTOR CHOICE

W/C Securement: (circle one) Q'Straint QRTMAX Sure-Lok

Event Data Recorder Channel System Selections

As detailed in Section 2.45 of the Technical Specifications, an event data recorder (EDR), Circuitlink International “Tacholink”, (or approved equal) will be mounted on each vehicle.

The EDR will provide a continuous log of vehicle activity. Speed history, odometer, excessive RPM, heavy braking, fast acceleration, and idling exceptions will be automatically recorded by exception. In the event of an accident, all data shall be permanently captured in “tamperproof” flash memory (4MB minimum) for a minimum of (30) seconds prior to the incident and (15) seconds after the incident at a minimum interval of 25 milliseconds.

The EDR will provide an automatic trigger function with different user definable thresholds for moving and stationary conditions. A manual driver alert button will be provided to allow driver “tagging” of either an accident or vehicle fault condition shall be located behind upper bulkhead and must be accessible through a latching door.

All software for user configuration, data logging, and downloading and report generation will be included. All software will be Windows-based. Trip data will be stored in Microsoft Access database. All data will be the property of Florida DOT and will be immediately available to Florida DOT. There will be no additional charges, for hardware and/or software services or annual fees will be incurred by Florida DOT or any operator.

Additional digital input channels will be provided to allow for status monitoring of a maximum of eight (8) vehicle sub-systems. Standard systems that will be monitored shall be: brakes, lights, signals, flashers, driver’s seat belt, wheelchair lift, engine temperature and front door. Each agency may substitute any of the standard systems detailed above with any of the following optional systems: oil pressure, low air pressure, low voltage, or emergency exit door. The limit of the total systems to be monitored is eight (8).

Below, please indicate the eight (8) vehicle sub-systems to be monitored on this vehicle. If no selection made, the standard systems will be programmed. For each of the optional systems you select, you must not include one of the standard system selections. A limit of eight (8) total systems per bus can be monitored.

Select Eight Systems To Be Monitored (Maximum of Eight (8))			
STANDARD SYSTEMS		OPTIONAL SYSTEMS	
XX	1. Brakes	XX	9. Oil Pressure
XX	2. Lights	XX	10. Low Air Pressure
XX	3. Signals		11. Low Voltage
	4. Flashers		12. Emergency Door Exit
	5. Driver’s Seat Belt		
XX	6. Wheelchair Lift		
XX	7. Engine Temperature		
XX	8. Front Door		

EXHIBIT C

OPTIONS

OPTIONS
CONTRACT # FVPP-08-SC-GM
ORDER FORM FOR GLAVAL SMALL CUTAWAYS

GETAWAY MARKETING, INC.

3.1.0 ALUMINUM WHEELS

3.1.1 Aluminum wheels in place of standard steel wheels.

3.2.0 ALTRO-TRANSIT FLOORING

3.2.1 Altro Transflor slip-resistant sheet vinyl flooring. Smooth, all welded seams, customer to supply color selection. Includes Altro step tread material with yellow nosing.

3.3.0 DIESEL ENGINE

3.3.1 Chevrolet 300 HP, 6.6L Duramax Diesel engine in place of the standard gasoline engine.

3.4.0 DRIVER PARTITION

3.4.1 To prevent passenger physical contact from behind the driver, install a 3/8" Lexan Plex shield wall, 4" below the ceiling to 36" above the floor; and a modesty panel from below the Lexan Plex shield frame to 3" above the floor, supported by stainless-steel tubing, similar in construction and design to the modesty panel adjacent to the front passenger door.

3.5.0 SEAT BELT EXTENSIONS

3.5.1 To extend the length of standard seat belts. Two seat belt extensions are offered as standard. Extra seat belt extensions may be purchased.

3.6.0 DRIVER'S SEAT

3.6.1 Freedman CL 67 air suspension driver's seat with right hand arm rest in place of standard driver's seat for increased driver comfort.

- 3.6.2 Freedman Sport Driver's seat with Relaxor, four zone eight motor system with lumbar heat in place of standard driver's seat for maximum driver comfort.

3.7.0 ENTERTAINMENT CENTER

- 3.7.1 An AM/FM/CD Stereo and MP3 Player with digital clock, and front, mid-bus and rear speakers.

3.8.0 PUBLIC ADDRESS SYSTEM

- 3.8.1 Install a Radio Engineering Industries (REI) public address system with hand-held microphone within easy reach of the driver with a microphone jack for optional hands-free use by driver. If an audio entertainment center (3.7.1) is installed, utilize its speakers in mid and rear bus and install a cancel switch to turn off entertainment center system when microphone transmit button is depressed by driver.

3.9.0 ADA MOBILITY DEVICES

- 3.9.1 Braun wheel chair lift (per Part 2).
3.9.2 Maxon wheel chair lift (per Part 2).
3.9.3 Ricon wheel chair lift (per Part 2).

3.10.0 STAINLESS STEEL WHEEL INSERTS

- 3.10.1 Bus shall be equipped with stainless steel wheel liners/inserts both front and rear. Wheel liners/inserts shall be Versa-Liner or equivalent. Wheel liners/inserts shall be made of 304L stainless with permanently attached simulated lug nuts attached without interfering with the lug nut to wheel surfaces.

3.11.0 REVERSE ASSISTANCE DETECTION SYSTEM

- 3.11.1 Rear energy absorbing Romeo Rim HELP bumper assembled with HawKEye Reverse Assistance System, (Romeo Rim Help Guard) in place of standard rear HELP bumper.

3.12.0 STRETCHER SECUREMENT SYSTEM

3.12.1 Install a stretcher securement system in the rear aisle of the bus. A lock-down system shall be installed in floor at the rear and front of the stretcher for securement of brackets that connect to the stretcher frame. A storage rack shall be installed at the rear interior corner(s) of the bus for the purpose of storing the brackets when not in use.

3.13.0 WHEELCHAIR OR MOBILITY AID RETRACTOR SYSTEM

3.13.1 Q'Straint QRTMax Securement System.

3.15.0 FIRE SUPPRESSION SYSTEM

3.15.1 Amerex powder or clear agent Fire Suppression System as an option to the JoMar clear agent Fire Suppression system, which is standard.

EXHIBIT D

EXTERIOR PAINT SCHEMES

EXTERIOR PAINT SCHEME #1

 <p>GLAVAL BUS Division of Forest River, Inc.</p>	<p>General Description</p> <p>PAINT SCHEMATIC I FLORIDA DOT</p>	<p>Model Type: SPART</p>	<p>Wheelbase: 129</p>	<p>Part Number: 8003196</p>	<p>Drawing Folder: FLOORS & ELEV</p>	<p>Date: 4/29/08</p>	<p>Drawn By: V. CLINE</p>
---	--	------------------------------	---------------------------	---------------------------------	--	--------------------------	-------------------------------

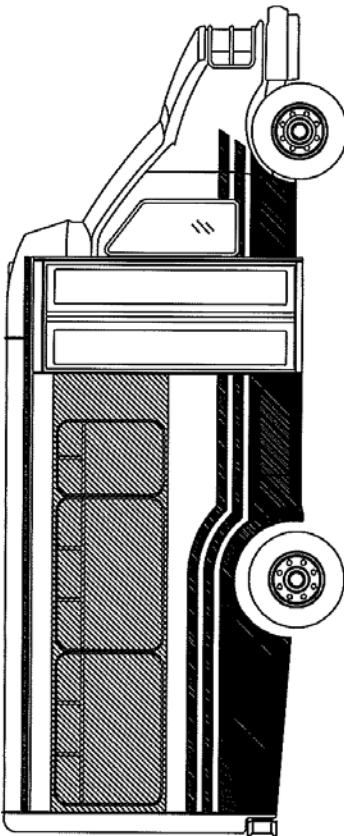

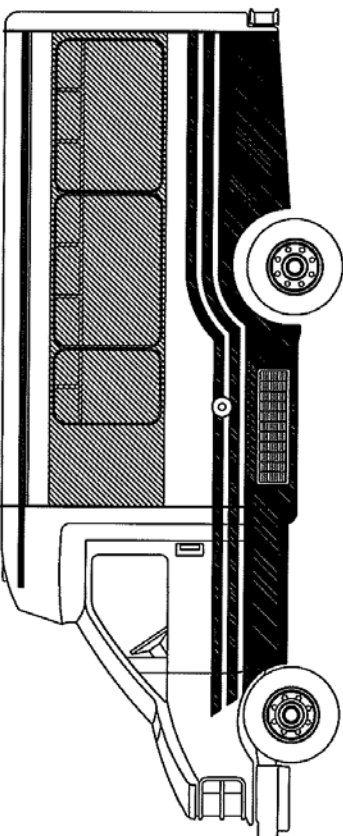

<p>RevNo Revision note</p>	<p>Date</p>	<p>Signature</p>	<p>Checked</p>
------------------------------	-------------	------------------	----------------

EXTERIOR PAINT SCHEME #2

 <p>GLAVAL BUS Division of Forest River Inc.</p>	<p>PAINT SCHEMATIC II FLORIDA DOT</p>	<p>Model Type: SP8T</p>	<p>Wheelbase: 139</p>	<p>Part Number: 8023196</p>	<p>Drawing Folder: FL008S & ELEV</p>	<p>Date: 4/9/08</p>	<p>DRAWN BY: V. CLINE</p>
--	---	-----------------------------	---------------------------	---------------------------------	--	-------------------------	-------------------------------

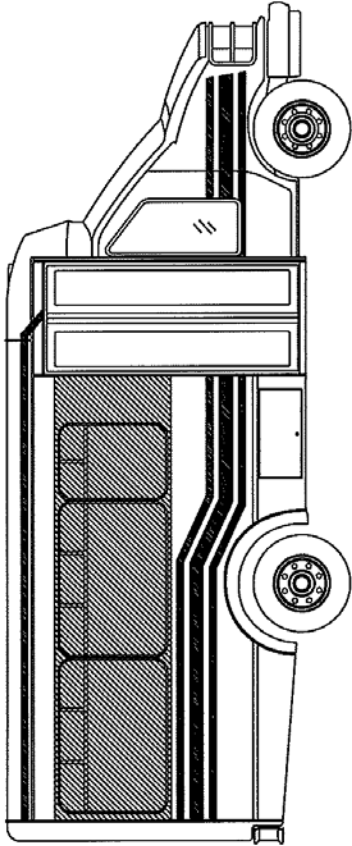

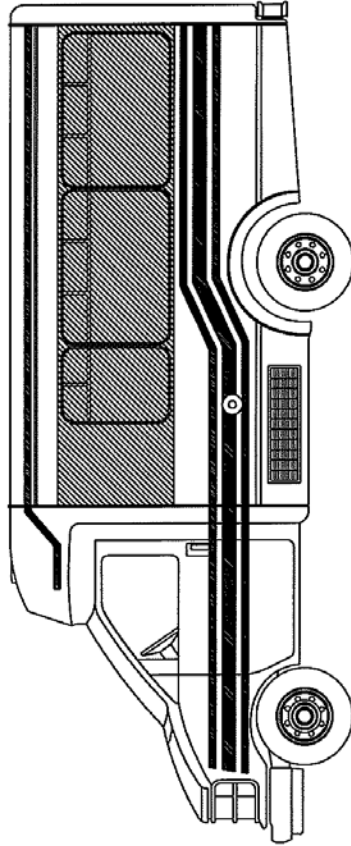

<p>RevNo</p>	<p>Revision note</p>	<p>Date</p>	<p>Signature/Checked</p>
--------------	----------------------	-------------	--------------------------

EXTERIOR PAINT SCHEME #3

 <p>GLVAL BUS Division of Pensacola Inc.</p>	<p>General Description</p> <p>PAINT SCHEMATIC III FLORIDA DOT</p>	<p>Model Type: SPBRT</p>	<p>Wheelbase: 139</p>	<p>Part Number: 8805196</p>	<p>Drawing Folder: FLBDS & LLEV</p>	<p>Date: 4/9/08</p>	<p>DRAWN BY: V. CLINE</p>
--	--	------------------------------	---------------------------	---------------------------------	---	-------------------------	-------------------------------

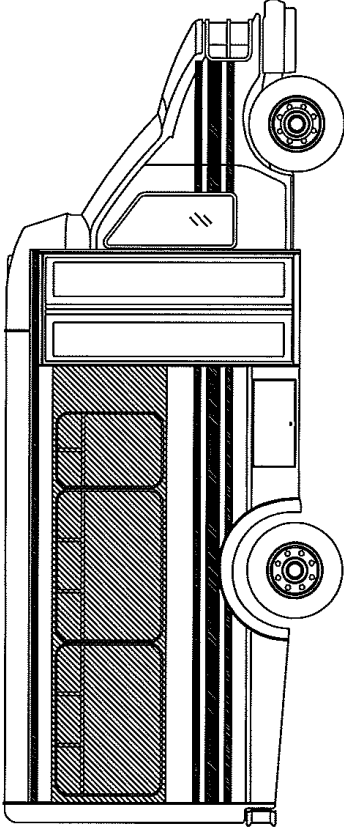

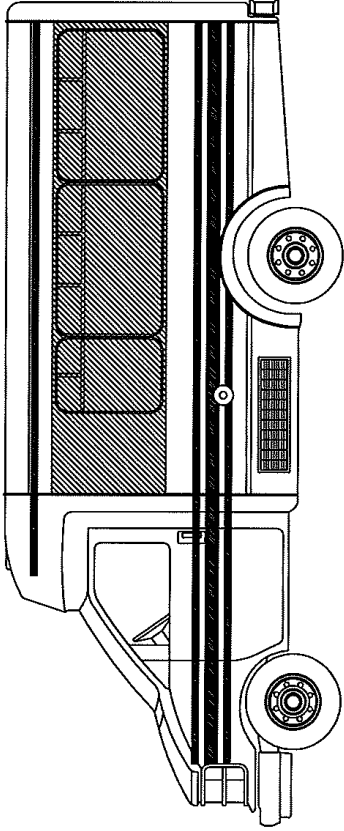

RevNo	Revision note	Date	Signature	Checked
-------	---------------	------	-----------	---------

EXHIBIT E

FLOOR PLAN LAYOUTS

Most agencies already have an idea on the type and number of seats and wheelchair positions needed to meet their floor plan requirements. A wide variety of alternative floor plans are available.

Agencies should work closely with Getaway Marketing, Inc. to develop and finalize their passenger seating floor layout plans. Based upon this consultation, Getaway Marketing, Inc. will develop a proposed floor plan based on the Agency's needs and fax a copy of the plan to the Agency for verification and approval.