

**RIVERS BUS  
REPRESENTING  
CHAMPION BUS, INC.**

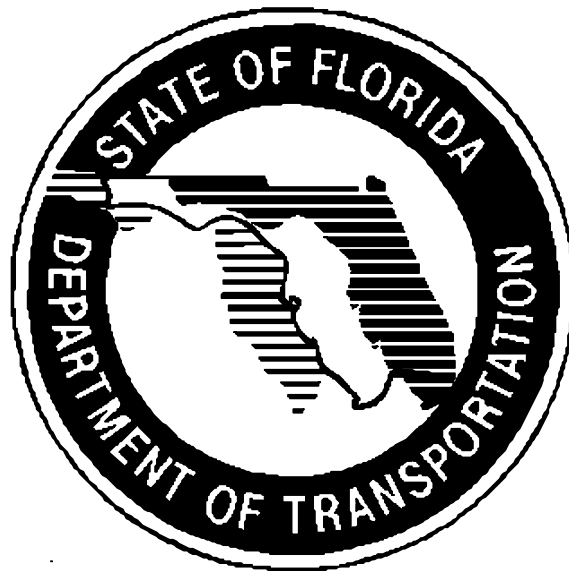

**ORDER PACKET**

**Contract #TRIPS-11-CA-RB  
Cutaway Type Vehicles**

**CONTRACT #TRIPS-11-CA-RB****ORDER PACKET FOR  
CHAMPION CUTAWAY TRANSIT VEHICLES  
RIVERS BUS****General Information**

The Transit Research Inspection Procurement Services Program (TRIPS) issued Proposal #TRIPS-11-CA-RFP to establish a series of state contracts for the purchase of Body on Chassis Cutaway Type Vehicles. Through this process six contracts were awarded to six different vendors each representing a vehicle manufacturer.

This Order Packet is for Contract #TRIPS-11-CA-RB, which was awarded to Rivers Bus on January 10, 2012 to provide Champion Cutaway Type Vehicles in various lengths and on various chassis' and chassis sizes.

This Order Packet contains the necessary instructions and forms for agencies to place an order with Rivers Bus to purchase these vehicles. This Order Packet also provides guidance and clarity on the relationships between the seller, the buyer, and Florida DOT's TRIPS program.

The complete Contract #TRIPS-11-CA-RB is accessible from the TRIPS website <http://www.tripsflorida.org> and contains the following sections:

- **Part 1** - General Requirements and Conditions, and Contractual Provisions  
*(Including all U.S. DOT Federal Transit Administration certifications)*
- **Part 2** - Technical Specifications
- **Part 3** - Options
- **Part 4** - Quality Assurance Provisions
- **Part 5** - Warranty Provisions
- **Part 6** - Paint Schemes

For further information on the TRIPS program and Contract #TRIPS-11-CA-RB, please contact either Edward Bart (813-974-6693) or Cindy Wooten (813-974-9771) at the University of South Florida, Center for Urban Transportation Research (CUTR).

## Vendor Information

To place an order for a vehicle under Contract #TRIPS-11-CA-RB, contact Mike McCullough at Rivers Bus:

- **Address:** 10626 General Ave  
Jacksonville, Florida 32220
- **Telephone #:** (800)-253-0224
- **Fax #:**
- **Web:** [www.riversbus.com](http://www.riversbus.com)
- **Contact Person:** Mike McCullough

## Procedures for Ordering

The following sections provide guidance to be used by the vendor and the agencies in the ordering, delivery, acceptance and payment for vehicles procured under this contract. All parties are advised to fully review the full contract document available on the TRIPS website. Contract #TRIPS-11-CA-RB will be the governing document.

Agencies should understand that each order placed with and acknowledged by Rivers Bus constitutes a contract between the purchaser and Rivers Bus only. The contract implies no duties or responsibilities by the University of South Florida, Center for Urban Transportation Research, or the Florida Department of Transportation. The terms and conditions of this contract are to be administered and enforced by and between the ordering agency and the vendor.

## ORDERING INSTRUCTIONS

Agencies must utilize the order forms in this Order Packet to place their orders. Agencies are encouraged to contact and work closely with Rivers Bus in finalizing their orders, to fully understand the options available, to select the floor plans and seating selections, the paint schemes, and any special options or conditions that may impact the final order and purchase price. Please submit a separate order form for each vehicle ordered.

Contract #TRIPS-11-CA-RB is to provide Champion Cutaway Type Vehicles in various lengths, with two chassis sizes. Among the standard components of this vehicle are:

- International chassis
- Heavy duty transmission
- Fire Suppression system
- Multiplex electrical system
- Electric door operation
- Multiple floor layouts and seating options
- Choice of wheelchair lift types and models, and securement systems
- Optional stretcher securement system
- Several standard paint schemes and options
- Several other options

Most agencies already have an idea on the type and number of seats and wheelchair positions needed to meet their floor plan requirements. A wide variety of floor plans are available. Agencies should work closely with Rivers Bus to develop and finalize their floor layout plans. Based upon this consultation, Rivers Bus will develop a proposed floor plan based on the Agency's needs and fax a copy of the plan to the Agency for verification and approval.

The Order Packet also includes illustrations of the basic vehicle paint schemes and the description of the available options to assist the Agency in completing your orders.

Included in this Order Packet are the following forms and information:

- Order Form that provides:
  - Base vehicle prices
  - Unit seating and wheelchair station prices
  - Paint scheme options and prices
  - Individual option and prices
  - Sample choice forms
- Sample Order Form – providing an example as how to complete the order form
- Description of Options
- Available Paint Schemes

Please submit a separate order form for each vehicle ordered. After determining the length of bus, floor plan, paint scheme and desired individual options, to complete the order form place the number of items in the corresponding quantity column. Multiply the dollar figure in the cost column by the number of items in the quantity column to calculate a total cost for that item. Enter that amount in the total cost column. Add the total cost column amounts together to arrive at the grand total for the vehicle. The grand total will be the figure used on the Agency's purchase order.

***Unless your vehicle is funded in part by the FTA Section 5310 grant program, the Agency deals directly with RIVERS BUS***

Once the details of the order are finalized, an Agency purchase order must accompany all orders placed with Rivers Bus for those vehicles not funded by the FTA Section 5310 grant program.

***For all vehicles funded through the FTA Section 5310 grant program***, a copy of the completed order form and either an Agency purchase order or a check for the Agency's portion payable to Rivers Bus must be emailed, faxed, or mailed to the CUTR Section 5310 Program Coordinator:

Ms. Cindy Wooten  
TRIPS Section 5310 Program Coordinator  
USF-CUTR  
4202 E. Fowler Avenue – CUT100  
Tampa, Florida 33620  
Telephone: (813) 974-9771

Fax: (813) 396-9345  
Email: [wooten@cutr.usf.edu](mailto:wooten@cutr.usf.edu)

The TRIPS Section 5310 Program Coordinator will verify the order accuracy, complete the request for the FDOT share, and forward the request to Tallahassee for the FDOT purchase order. When the FDOT purchase order number is assigned, the TRIPS Section 5310 Program Coordinator will place the order with Rivers Bus and notify the Agency of its status.

Rivers Bus will provide written confirmation to the Agency and/or CUTR of the receipt of the order within seventy-two (72) hours of receiving the order with purchase order. At a minimum, the acknowledgement of the order will contain:

- The Agency's purchase order number
- The date the order was received
- The date the order was placed with the manufacturer
- The production and VIN number when available
- The estimated delivery date (when available)

### **DELIVERY**

Completed units must be delivered to Agency within ninety (90) days from receipt of chassis or purchase order, whichever occurs last.

In the event of delay in completion of the delivery of vehicles beyond the date specified in the contract, in addition to any granted extensions agreed to in writing by the Agency, the Agency may assess as liquidated damages, twenty five dollars (\$25.00) per calendar day per vehicle.

Each vehicle purchased through the TRIPS shall be routed to the FDOT's Springhill Inspection Facility, located in Tallahassee, Florida, for an inspection prior to delivery to Rivers Bus.

Rivers Bus should see that all noted write-ups are corrected prior to final delivery to the procuring agency. This inspection by the TRIPS is not represented as being "all inclusive" and in no way relieves the dealer from the required Pre-Delivery Inspection (PDI).

Prior to the vehicle(s) being delivered, Rivers Bus must perform a PDI. Upon completion of a PDI, Rivers Bus will be required to deliver the vehicles to the Purchaser. The dealer shall notify both the purchasing Agency and the FDOT District Office a minimum of 48 hours in advance to arrange a delivery time.

The vehicle shall be delivered with all Contractor/manufacturer's quality control checklists including road test and final inspection (properly completed and signed by an authorized plant representative). Other documents/items required at delivery include:

- Manufacturer's Certificate of Origin
- Application for Certificate of Title

- 2012 Pricing
- Bill of Sale
  - Warranty Papers (forms, policy, procedures)
  - Maintenance Schedule
  - Operators' manual
  - Invoice (To include contract number, P.O. number, VIN#, and agency name)

## **FINAL ACCEPTANCE**

Delivery of the vehicle(s) by Rivers Bus does not constitute acceptance by the Agency. The vehicle will be considered "accepted" upon passing the inspection and issuance of an acceptance letter by the Agency.

The terms of the contract state that an Agency has ten (10) calendar days after receiving the vehicle(s) to perform the Post Delivery Inspection and issue either a "Letter of Acceptance" or a "Letter of Rejection" to Rivers Bus and the Florida DOT District Office contact. The "Letter of Rejection" will state and describe the areas to be found in noncompliance with the bid specifications, incompleteness, or any defective or damaged parts.

A vehicle should be rejected if any items are missing, defective, altered, incorrect, or incomplete. In the event a vehicle(s) is delivered incomplete or contains any defective or damaged parts, the said parts will be removed and replaced by Rivers Bus. New parts will be furnished and installed by Rivers Bus at no cost to the Agency. If there is work involved, warranty or otherwise, to repair or place the vehicle(s) in proper complete condition, such repairs will be made by an approved firm in accordance to the warranty provisions of the contract.

Placing the vehicle(s) in revenue service will automatically constitute "acceptance". In such circumstances, a "Letter of Acceptance" should still be sent to Rivers Bus.

Acceptance of the vehicles shall not release the Contractor from liability for faulty workmanship or materials.

## **PAYMENT**

***For vehicle purchased without funding from the FTA Section 5310 grant program,*** the Agency should complete all necessary paperwork and submit its request to process the Agency purchase order payment within five (5) days after the delivery and/or acceptance of the vehicle.

***For all vehicles funded through the FTA Section 5310 grant program,*** the Agency should approve and process its purchase order to allow a check for the Agency amount to be sent to Rivers Bus for its share of the vehicle. If, instead of a purchase order, a check was provided at the order request time, forward all invoices to the CUTR Section 5310 Program Coordinator along with the acceptance letter.

Upon receipt of the Agency's portion of the vehicle, Rivers Bus will contact the CUTR Section 5310 Program Coordinator with a request to process the FDOT purchase order payment approval.

***The total purchase price should be paid in full within sixty (60) days after acceptance of each vehicle.*** Agencies should note that failure to meet the net 60-day payment terms could result in the assessment of interest and other penalties. Terms are those shown in Price Proposal Form F of the contract document. A 2% monthly service charge will be added to all past due accounts.

# **EXHIBIT A**

# **ORDER FORM**

**ORDER FORM – PAGE ONE**

**CONTRACT #TRIPS-11-CA-RB**

**ORDER FORM FOR CHAMPION CUTAWAY TRANSIT VEHICLES**

**RIVERS BUS**

**AGENCY NAME:** \_\_\_\_\_ **DATE:** \_\_\_\_\_

**PURCHASE ORDER NUMBER:** \_\_\_\_\_

**CONTACT PERSON:** \_\_\_\_\_  
*(Name, Telephone Number and Email Address)*

January 2012

Item	Unit Cost	Quantity	Total Cost
<b>Base Vehicle Type</b>			
International 19500 GVWR 24' MF7 6.4L Diesel	\$86,955		
<i>25' Option add</i>	\$1,177		
<i>28' Option add</i>	\$7,600		
<i>32' Option add</i>	\$13,832		
International 26000 GVWR 32' MF7 6.4L Diesel	\$121,693		
<i>36' Option add</i>	\$3,055		
<i>38' Option add</i>	\$5,070		
<b>Paint Scheme Choices</b>			
Scheme #1	\$350		
Scheme #2	\$325		
Scheme #3	\$325		
<b>Base Seating (Freedman)</b>			
Standard Seat <i>(per person)</i>	\$240		
Foldaway Seat <i>(per person)</i>	\$275		
Children's Seat <i>(per person)</i>	\$675		
<b>Securement Systems</b>			
Q'Straint QRTMAX securement <i>(per position)</i>	\$475		
Sure-Lok Titan securement <i>(per position)</i>	\$575		
Seat belt extensions <i>(2-sets standard)</i>	\$15		
<b>PAGE ONE SUB-TOTAL</b>	----	----	

**ORDER FORM – PAGE TWO****CONTRACT #TRIPS-11-CA-RB****ORDER FORM FOR CHAMPION CUTAWAY TRANSIT VEHICLES****RIVERS BUS**

January 2012

Item	Unit Cost	Qty	Total Cost
<b>Side Wheelchair Lift Choices</b>			
Braun Model NCL919IB-2 (or latest)	\$4,250		
Maxon Model WL-6A3353 (or latest)	\$4,650		
Ricon Model S5510 (or latest)	\$4,250		
<b>Rear Wheelchair Lift Choices</b>			
Ricon Klear-View lift <u>(prior approval from FDOT required)</u>	\$4,485		
Braun model NVL917IB lift <u>(prior approval from FDOT required)</u>	\$4,465		
<b>Optional Engines</b>			
Diesel engine meeting current EPA requirements			
215 HP MaxxForce DT 7.6 Diesel	\$2,100		
Compressed Natural Gas (CNG) Engine meeting current EPA requirements	N/A		
Size: _____ Make: _____ Manufacturer: _____			
Aluminum wheels: 19,000 = (\$1,305), 26,000 = (\$1,670)	See Item		
Stainless steel wheel liners / inserts, front and rear wheels	\$ 360		
<b>Seating</b>			
Freedman Featherweight High Back standard seats (per seat)	\$250		
Dimensions vinyl line of coated transit bus seating fabric with antimicrobial Nanocide	\$30		
Upgrade interior side wall panels with Nanocide: 27 ft and below = (\$1,000); over 27 ft = (\$1,500)	See Item		
USSC Evolution G2E with pedestal	N/A		
Freedman Sport Driver seat with Relaxor	N/A		
Stretcher Securement System	\$950		
Replacement Stretcher bed (only)	\$6,000		
<b>PAGE TWO SUB-TOTAL</b>	----	----	

**ORDER FORM – PAGE THREE****CONTRACT #TRIPS-11-CA-RB****ORDER FORM FOR CHAMPION CUTAWAY TRANSIT VEHICLES****RIVERS BUS**

January 2012

Item	Unit Cost	Qty	Total Cost
<b>Fire Suppression</b>			
Amerex Small Vehicle System automatic fire suppression powder system	Deduct \$1,125		
Kidde Automatic Fire Detection and Suppression System	Deduct \$300		
<b>Route/Head Signs</b>			
Transign manually operated roller curtain type sign	\$2,350		
TwinVision "Elyse" software electronic destination system	\$6,025		
TwinVision "Mobi-Lite" electronic destination sign	\$3,385		
Transign "Vista Star" electronic destination sign	\$4,307		
Transign LLC 2-digit Block / Run Number box unit	\$290		
Transign LLC 3-digit Block / Run Number box unit	\$295		
Transign LLC passenger " <b>STOP REQUESTED</b> " sign	\$175		
<b>Camera Systems</b>			
SEON 2 camera security system	\$1,765		
REI 2 camera security system	\$1,808		
Gatekeeper 2 camera security system	\$2,327		
AngelTrax 2 camera security system	\$2,304		
Apollo 2 camera security system	\$4,500		
247 2 camera security system	\$4,200		
Price for single replacement camera	\$200		
<b>Other Options Available</b>			
Altro Transflor slip resistant vinyl flooring: [19,000 lb] 24 ft = (\$840), 25 ft = (\$875), 28 ft = (\$980), 32 ft = (\$1,120): [26,000 lb] 32 ft = (\$1,080), 36 ft = (\$1,225), 38 ft = (\$1,330)	See Item		
Driver Safety Partition	\$205		
Bentec Powder-Coated handrails and stanchions (yellow)	\$600		
Exterior remote controlled mirrors	\$825		
Romeo Rim HELP rear bumper	\$700		
HawKEye Reverse Assistance System	\$400		
<b>PAGE THREE SUB-TOTAL</b>	----	----	

## ORDER FORM – PAGE FOUR

CONTRACT #TRIPS-11-CA-RB

### ORDER FORM FOR CHAMPION CUTAWAY TRANSIT VEHICLES

#### RIVERS BUS

January 2012

Reverse camera and monitor backing system: <i>Manufacturer</i> <u>ASA</u>	\$275		
Air purification system	\$2,700		
“Mentor Ranger” in vehicle computer	\$4,400		
REI Public Address System	\$300		
Upgrade the standard vehicle AM/FM Radio	\$405		
“Talking Bus” Basic System	\$27,000		
<b>PAGE FOUR SUB-TOTAL</b> <i>(sub-total of fourth page)</i>			
<b>PAGE THREE SUB-TOTAL</b> <i>(sub-total of third page)</i>			
<b>PAGE TWO SUB-TOTAL</b> <i>(sub-total of second page)</i>			
<b>PAGE ONE SUB-TOTAL</b> <i>(sub-total of first page)</i>			
<b>GRAND TOTAL</b> <i>(sum of pages 1, 2, 3, and 4 sub-totals)</i>			

**CHOICES FORM****CONTRACT #TRIPS-11-CA-RB****ORDER FORM FOR CHAMPION CUTAWAY TRANSIT VEHICLES****RIVERS BUS****SEATING AND FLOORING CHOICES**

**Seating Colors:** (circle one) Blue Gray Beige

**Flooring Colors:** (circle one) Blue Gray Beige Black

**Paint Scheme:** (circle one) #1 #2 #3 Other

**Paint Schemes Note:** If an agency requires a paint and lettering scheme that is NOT GENERALLY covered by one of those listed above, they may make separate arrangements either with the manufacturer or a local vendor to provide these services. Agencies will select colors (2) for background and stripes when orders are placed. All paint scheme pricing shall reflect white base coat.

***Upholstery Information-Vinyl Colors Available:***

**BLUE CMI VINYL** - Center insert of seat to be MEDALLION KEOPS AZUL BLUE INSERT, style VP-MEDLI-KEAZU; outside wrap and back of seat to be solid MEDALLION MORRENO TROPICAN AZUL, style VP-MEDMO-TRAZU.

**BEIGE CMI VINYL** - Center insert of seat to be MEDALLION KEOPS VERDE TAN INSERT, style VP-MEDLI-KEVER; outside wrap and back of seat to be solid, MEDALLION DOCCA SAND BEIGE, style VP-MEDLI-DOSNB.

**GREY CMI VINYL** - Center insert of seat to be MEDALLION KEOPS VERDE TAN INSERT, style VP-MEDLI-KEVER; outside wrap and back of seat to be solid, MEDALLION MORRENO TROPICAN GREY, style VP-MEDMO-TRGRY.

**WHEELCHAIR LIFT CHOICE**

**Wheelchair Lift:** (circle one) Braun Ricon Maxon

**SECUREMENT RETRACTOR CHOICE**

**W/C Securement:** (circle one) Sure-Lok Titan Q'Straint QRTMAX

# **EXHIBIT B**

## **SAMPLE ORDER FORM**

## SAMPLE ORDER FORM – PAGE ONE

CONTRACT #TRIPS-11-CA-RB

## ORDER FORM FOR CHAMPION CUTAWAY TRANSIT VEHICLES

## RIVERS BUS

AGENCY NAME: \_\_\_\_\_ DATE: \_\_\_\_\_

PURCHASE ORDER NUMBER: \_\_\_\_\_

CONTACT PERSON: \_\_\_\_\_  
(Name, Telephone Number and Email Address)

January 2012

Item	Unit Cost	Quantity	Total Cost
<b>Base Vehicle Type</b>			
International 19500 GVWR 24' MF7 6.4L Diesel	\$86,955	1	\$86,955
25' Option add	\$1,177		
28' Option add	\$7,600		
32' Option add	\$13,832		
International 26000 GVWR 32' MF7 6.4L Diesel	\$121,693		
36' Option add	\$3,055		
38' Option add	\$5,070		
<b>Paint Scheme Choices</b>			
Scheme #1	\$350	1	\$350
Scheme #2	\$325		
Scheme #3	\$325		
<b>Base Seating (Freedman)</b>			
Standard Seat (per person)	\$240	10	\$2,400
Foldaway Seat (per person)	\$275	2	\$550
Children's Seat (per person)	\$675		
<b>Securement Systems</b>			
Q'Straint QRTMAX securement (per position)	\$475	2	\$950
Sure-Lok Titan securement (per position)	\$575		
Seat belt extensions (2-sets standard)	\$15		
<b>PAGE ONE SUB-TOTAL</b>	----	----	<b>\$91,205</b>

**SAMPLE ORDER FORM – PAGE TWO****CONTRACT #TRIPS-11-CA-RB****ORDER FORM FOR CHAMPION CUTAWAY TRANSIT VEHICLES****RIVERS BUS**

January 2012

Item	Unit Cost	Qty	Total Cost
<b>Side Wheelchair Lift Choices</b>			
Braun Model NCL919IB-2 (or latest)	\$4,250	1	\$4,250
Maxon Model WL-6A3353 (or latest)	\$4,650		
Ricon Model S5510 (or latest)	\$4,250		
<b>Rear Wheelchair Lift Choices</b>			
Ricon Klear-View lift <u>(prior approval from FDOT required)</u>	\$4,485		
Braun model NVL917IB lift <u>(prior approval from FDOT required)</u>	\$4,465		
<b>Optional Engines</b>			
Diesel engine meeting current EPA requirements			
215 HP MaxxForce DT 7.6 Diesel	\$2,100		
Compressed Natural Gas (CNG) Engine meeting current EPA requirements	N/A		
Size: _____ Make: _____ Manufacturer: _____			
Aluminum wheels: 19,000 = (\$1,305), 26,000 = (\$1,670)	See Item		
Stainless steel wheel liners / inserts, front and rear wheels	\$ 360		
<b>Seating</b>			
Freedman Featherweight High Back standard seats (per seat)	\$250		
Dimensions vinyl line of coated transit bus seating fabric with antimicrobial Nanocide	\$30		
Upgrade interior side wall panels with Nanocide: 27 ft and below = (\$1,000); over 27 ft = (\$1,500)	See Item		
USSC Evolution G2E with pedestal	N/A		
Freedman Sport Driver seat with Relaxor	N/A		
Stretcher Securement System	\$950		
Replacement Stretcher bed (only)	\$6,000		
<b>PAGE TWO SUB-TOTAL</b>	----	----	<b>\$4,250</b>

## SAMPLE ORDER FORM – PAGE THREE

CONTRACT #TRIPS-11-CA-RB

### ORDER FORM FOR CHAMPION CUTAWAY TRANSIT VEHICLES

#### RIVERS BUS

January 2012

Item	Unit Cost	Qty	Total Cost
<b>Fire Suppression</b>			
Amerex Small Vehicle System automatic fire suppression powder system	Deduct \$1,125		
Kidde Automatic Fire Detection and Suppression System	Deduct \$300		
<b>Route/Head Signs</b>			
Transign manually operated roller curtain type sign	\$2,350		
TwinVision "Elyse" software electronic destination system	\$6,025		
TwinVision "Mobi-Lite" electronic destination sign	\$3,385		
Transign "Vista Star" electronic destination sign	\$4,307		
Transign LLC 2-digit Block / Run Number box unit	\$290		
Transign LLC 3-digit Block / Run Number box unit	\$295		
Transign LLC passenger " <b>STOP REQUESTED</b> " sign	\$175		
<b>Camera Systems</b>			
SEON 2 camera security system	\$1,765		
REI 2 camera security system	\$1,808	1	\$1,808
Gatekeeper 2 camera security system	\$2,327		
AngelTrax 2 camera security system	\$2,304		
Apollo 2 camera security system	\$4,500		
247 2 camera security system	\$4,200		
Price for single replacement camera	\$200		
<b>Other Options Available</b>			
Altro Transflor slip resistant vinyl flooring: [19,000 lb] 24 ft = (\$840), 25 ft = (\$875), 28 ft = (\$980), 32 ft = (\$1,120): [26,000 lb] 32 ft = (\$1,080), 36 ft = (\$1,225), 38 ft = (\$1,330)	See Item		
Driver Safety Partition	\$205		
Bentec Powder-Coated handrails and stanchions ( <i>yellow</i> )	\$600		
Exterior remote controlled mirrors	\$825		
Romeo Rim HELP rear bumper	\$700		
HawKEye Reverse Assistance System	\$400		
<b>PAGE THREE SUB-TOTAL</b>	----	----	<b>\$1,808</b>

**SAMPLE ORDER FORM – PAGE FOUR****CONTRACT #TRIPS-11-CA-RB****ORDER FORM FOR CHAMPION CUTAWAY TRANSIT VEHICLES****RIVERS BUS**

January 2012

Reverse camera and monitor backing system: <i>Manufacturer</i> <u>ASA</u>	\$275		
Air purification system	\$2,700		
"Mentor Ranger" in vehicle computer	\$4,400		
REI Public Address System	\$300		
Upgrade the standard vehicle AM/FM Radio	\$405		
"Talking Bus" Basic System	\$27,000		
<b>PAGE FOUR SUB-TOTAL</b> <i>(sub-total of fourth page)</i>	----	----	\$0
<b>PAGE THREE SUB-TOTAL</b> <i>(sub-total of third page)</i>	----	----	\$1,808
<b>PAGE TWO SUB-TOTAL</b> <i>(sub-total of second page)</i>	----	----	\$4,250
<b>PAGE ONE SUB-TOTAL</b> <i>(sub-total of first page)</i>	----	----	\$91,205
<b>GRAND TOTAL</b> <i>(sum of pages 1, 2, 3, and 4 sub-totals)</i>	----	----	\$97,263

**SAMPLE CHOICES FORM**

**CONTRACT #TRIPS-11-CA-RB**

**ORDER FORM FOR CHAMPION CUTAWAY TRANSIT VEHICLES**

**RIVERS BUS**

**SEATING AND FLOORING CHOICES**

**Seating Colors:** (circle one) Blue      Beige      Gray

**Flooring Colors:** (circle one) Blue      Beige      Gray      Black

**Paint Scheme:** (circle one) #1      #2      #3      Other

**Paint Schemes Note:** If an agency requires a paint and lettering scheme that is NOT GENERALLY covered by one of those listed above, they may make separate arrangements either with the manufacturer or a local vendor to provide these services. Agencies will select colors (2) for background and stripes when orders are placed. All paint scheme pricing shall reflect white base coat.

***Upholstery Information-Vinyl Colors Available:***

**BLUE CMI VINYL** - Center insert of seat to be MEDALLION KEOPS AZUL BLUE INSERT, style VP-MEDLI-KEAZU; outside wrap and back of seat to be solid MEDALLION MORRENO TROPICAN AZUL, style VP-MEDMO-TRAZU.

**BEIGE CMI VINYL** - Center insert of seat to be MEDALLION KEOPS VERDE TAN INSERT, style VP-MEDLI-KEVER; outside wrap and back of seat to be solid, MEDALLION DOCCA SAND BEIGE, style VP-MEDLI-DOSNB.

**GREY CMI VINYL** - Center insert of seat to be MEDALLION KEOPS VERDE TAN INSERT, style VP-MEDLI-KEVER; outside wrap and back of seat to be solid, MEDALLION MORRENO TROPICAN GREY, style VP-MEDMO-TRGRY.

**WHEELCHAIR LIFT CHOICE**

**Wheelchair Lift:** (circle one)      Braun      Ricon      Maxon

**SECUREMENT RETRACTOR CHOICE**

**W/C Securement:** (circle one)      Sure-Lok Titan      Q'Strait QRTMAX

# **EXHIBIT C**

# **OPTIONS**

## OPTIONS

### CONTRACT #TRIPS-11-CA-RB

#### CHAMPION CUTAWAY TRANSIT VEHICLES

#### RIVERS BUS

#### **3.2.2.0 ALTERNATIVE ENGINE, DIESEL, HYBRID OR MULTI- FUEL**

- 3.2.2.2 Diesel engine meeting current EPA requirements in place of the standard gasoline engine. Engine must meet standards described in Part 2, Section 2.2.2.
- 3.2.2.3 A Compressed Natural Gas (CNG) engine meeting current EPA requirements in place of the standard gasoline engine. Engine must meet standards described in Part 2, Section 2.2.3.

#### **3.2.9.0 WHEELS**

- 3.2.9.1 Provide Aluminum wheels in place of standard steel wheels.
- 3.2.9.2 Equip bus with stainless steel wheel liners / inserts on both front and rear wheels. Liner / inserts shall be Versa-Liner or approved equal, and made of 304L stainless steel with permanently attached simulated lug nuts. The simulated lug nuts shall not interfere with the actual lug nut to wheel contact surfaces.

#### **3.2.21.0 SEATS, BELT EXTENSIONS, & SEAT UPHOLSTERY**

- 3.2.21.6 Freedman Seating Featherweight High Back rigid frame seats.
- 3.2.21.8 Provide all Freedman Featherweight or 3-PT passenger seat with Dimensions vinyl line of coated transit bus seating fabric with antimicrobial Nanocide, by CMI Enterprises, or approved equal. Fabric to be CMI DIMENSIONS LATE EVENING, style VP-DIMEN-LEVEN or CMI DIMENSIONS CHARCOAL, style VP-DIMEN-CHAR or approved equal.
- 3.2.21.9 Upgrade interior side wall panels with Nanocide antimicrobial fabric CMI DIMENSIONS CHARCOAL, style VP-DIMEN-CHAR. Upgrade interior side wall panels from the ceiling light fixtures down to the seat track, or 12 inches (12") above the floor covering.
- 3.2.21.10 Extend the length of the standard seat belts provided. Two seat belt extensions are to be provided as standard. A third or more seat belt extensions may be purchased.

**3.2.24.0 DRIVER'S SEAT**

- 3.2.24.2 USSC Evolution G2E with pedestal (not currently available)
- 3.2.24.3 Freedman Sport Driver's seat with Relaxor, four zone eight motor system with lumbar heat in place of standard driver's seat. (not currently available)

**3.2.25.0 NON-SLIP TRANSIT FLOORING**

- 3.2.25.3 Provide Altro Transflor slip resistant sheet vinyl flooring with smooth, all welded seams. Each customer will determine color / design selection. Include Altro step tread material with *yellow* step nosing and *white* "standee line" insert.

**3.2.26.0 DRIVER SAFETY PARTITION**

- 3.2.26.3 To prevent passenger physical contact with the driver, install a 1/4" Lexan, or approved equal, shield wall, 3" below the ceiling to 36" above the floor; and a modesty panel from below the Lexan Plex shield frame to 3" above the floor, supported by stainless-steel tubing, similar in construction and design to the modesty panel adjacent to the front passenger door. Unit shall be designed to permit attachment of customer notification panel and/or pamphlet holder units.

**3.2.27.0 GRAB RAILS AND STANCHIONS**

- 3.2.27.6 Powder-Coated handrails and stanchions to match the vehicle interior and manufactured by Bentec, Inc, or approved equal.

**3.2.31.0 REMOTE EXTERIOR MIRRORS**

- 3.2.31.5 Provide right and left side exterior remote controlled mirrors, adjustable from the driver's seat.

**3.2.34.0 BUMPERS & REVERSE ASSISTANCE DETECTION SYSTEM**

- 3.2.34.2 Rear energy absorbing Romeo Rim HELP bumper assembled without HawKEye Reverse Assistance System, (Romeo Rim Help Guard) in place of standard rear steel bumper.
- 3.2.34.2.1 HawKEye Reverse Assistance System
- 3.2.34.3 Reverse camera and monitor backing system, in lieu of HawkEye System above.

**3.2.36.0 Air Purification System**

- 3.2.36.6 The air purification system shall be JKA Company, BREATH SAFE SYSTEMS or approved equal. The system shall be designed for Paratransit bus application to eliminate the spread of virus, bacteria, odors, mold and fungus growth within the bus air conditioning evaporator coils and drain pan.

### **3.2.37.0 ADA MOBILITY DEVICES**

- 3.2.37.3 Ricon Klear-View lift (prior approval from FDOT required)
- 3.2.37.3.1 Braun model NVL9171B lift (prior approval from FDOT required)
- 3.2.37.3.2 Ricon Model S5510
- 3.2.37.3.3 Braun Model NCL9191B-2
- 3.2.37.3.4 Maxon Model WL-6A3353

### **3.2.38.0 SECUREMENT DEVICES**

- 3.2.38.3 SURE-LOK Titan restraint system
- 3.2.38.3.1 Q'straint QRTMAX restraint system
- 3.2.38.14 Install a stretcher securement system in the rear aisle of the bus. A lock-down system shall be installed in floor at the rear and front of the stretcher for securement of brackets that connect to the stretcher frame. A storage container(s) shall be securely installed at the rear interior corner(s) of the bus for the purpose of storing the brackets when not in use. With this option, the air ride system should be adjusted down to reduce the ground-to-floor distance. Provide the accompanying stretcher bed for the securement system described above.
- 3.2.38.15 Replacement Stretcher bed (only) as an option

### **3.2.39.0 SAFETY EQUIPMENT**

- 3.2.39.9 Amerex Small Vehicle System (SMVS), a complete turn-key automatic fire suppression powder system, or approved equal.
- 3.2.39.9.1 Kidde Fire Suppression System, a complete turn-key automatic fire suppression system, or approved equal.
- 3.2.39.11 "*Mentor Ranger*", an in-vehicle computer, manufactured by Mentor, that allows electronic delivery of passenger manifests, automatic data collection, in-vehicle navigation, and enhanced driver/dispatcher communication. The system shall be capable of integration to other on-board systems, including existing APC, IVR and GPS onboard units, and shall be a turn-key installation.

### **3.2.40.0 PA & ENTERTAINMENT SYSTEMS**

- 3.2.40.2 Install a Radio Engineering Industries (REI) public address system with hand-held microphone within easy reach of the driver with a microphone jack for optional hands-free use by driver. If an audio entertainment center (**3.2.40.3**) is installed, utilize its speakers in mid and rear bus and install a cancel switch to turn off entertainment center system when microphone transmit button is depressed by driver. Provide a 20' long microphone extension cord and provide a microphone jack adjacent to the front curb-side seat.
- 3.2.40.3 Upgrade the standard vehicle AM/FM Radio, providing a AM/FM/CD Stereo and MP3 Player with digital clock, with front, mid-bus and rear speakers, or approved equal quality.

### **3.2.41.0 DESTINATION SIGNS**

- 3.2.41.2 A manually operated destination sign for limited destination readings shall be offered. Front destination sign shall be a Transign LLC, single roller curtain type installed above the windshield with a glass exposure of 8 inches x 60 inches. The side destination sign for a front door only bus will be a single roller type installed in the upper curbside window immediately behind the entrance door with a glass exposure of 5-3/4" x 28". The side destination sign for a front and rear door bus shall be installed in the upper curbside window immediately in front of the rear door. Destination signs will be electrically operated, LED, fluorescent or incandescent backlit display, single curtain, .003 mil. thick Mylar anti-glare material, with provisions for a minimum of 25 readings and a maximum of 175 readings of 5 inch high Helvetica medium font letters for the front sign and Helvetica medium font letters 4" high characters for the side sign. Control switch is to be located on the left hand of the driver's console. Curtain destination signs will conform to the Americans With Disabilities Act Part 38. Characters on these signs will have a width-to-height ratio between 3:5 and 1:1 and a stroke width-to-height ratio between 1:5 and 1:10. Generally, the space between letters will be 1/16 the height of upper case letters and will contrast with the background using either yellow letters on green or black background; or white letters on red, green, blue or black background per the purchaser's choice, for route and destination identification. The following destination readings will be standard on all destination signs ordered under this contract, with colors noted:

**Bus Garage** (yellow letters on black background)  
**Not In Service** (yellow letters on black background)  
**Special Service** (yellow letters on black background)  
**Shuttle Service** (yellow letters on black background)  
**Downtown** (yellow letters on green background)  
**Town Center** (yellow letters on green background)  
**Public Transportation** (yellow letters on green background)  
**Emergency Service** (white letters on red background)  
**Emergency Shelter** (white letters on red background)  
**Evacuation Route** (white letters on red background)

**Express** (white letters on red background)

- 3.2.41.3 Twin Vision Elyse software Electronic Destination system full front and side signs; and a separate rear number only sign shall be provided. The system shall be compatible with Windows 2000 or Windows XP software, using IBM 486 or higher PC/AT capacity, PCMCIA memory download technology. Electronic destination signs will conform to the Americans With Disabilities Act Part 38. The electronic destination sign shall utilize Helvetica yellow medium lettering on black background. The readings listed in 3.2.41.2 above shall also be standard in all Elyse electronic destination signs ordered under this contract.
- 3.2.41.4 A Twin Vision Mobi-Lite electronic destination sign, or approved equal, with side destination sign, using amber LED's and has fully programmable features that allow both large single and double line capabilities. The readings listed in 3.2.41.2 above shall also be standard in all Mobi-Lite electronic signs ordered under this contract.
- 3.2.41.5 A Transign Vista Star electronic destination sign, or approved equal, with side destination sign, using amber LED's and has fully programmable features that allow both large single and double line capabilities. The readings listed in 3.2.41.2 above shall also be standard in all Transign electronic signs ordered under this contract.
- 3.2.41.6 A Transign LLC 2-digit incandescent backlight, with anti-glare finish, dash mounted Block/Run Number Box, or approved equal, shall be provided. White, red or yellow LED letters/numbers on a black background, displayed in a plastic or metal frame, to operate on a 12 volt system.
- 3.2.41.7 A Transign LLC 3-digit incandescent backlight, with anti-glare finish, dash mounted Block/Run Number Box, or approved equal, shall be provided. White, red or yellow LED letters/numbers on a black background, displayed in a plastic or metal frame, to operate on a 12 volt system.
- 3.2.41.8 A "STOP REQUESTED" sign, as manufactured by Transign LLC, or approved equal, installed in the front vestibule area. Sign is activated by passengers and de-activates with the opening of the passenger entry door. Injected molded with display area of 2.5 X 19.75 minimum. Provide a silk screened lens display face with yellow letters on green background, or as required by Purchaser.

**3.2.42.0 LIST OTHER MANUFACTURER OPTIONS AVAILABLE FOR CONSIDERATION**

- 3.2.42.1 SEON 2 camera security system
- 3.2.42.2 REI 2 camera security system
- 3.2.42.3 Gatekeeper 2 camera security Solid State Bus Video System 32 GB SD Card

- 3.2.42.4 AngelTrax 2 camera security system
- 3.2.42.5 Apollo 2 camera security system -120ips Mobile DVR, 1.0TB Removable HDD
- 3.2.42.6 247 2 camera security system, 16GB Solid-State Flash Storage, mDVR  
TVS22 w/2 Camera [15 hours storage]
- 3.2.42.7 Provide replacement surveillance camera

# **EXHIBIT D**

# **PAINT SCHEMES**

# EXTERIOR PAINT SCHEME #1

Scheme I Blackout Windows

Paint Scheme DF 31' RL 217 WB yellow tyans

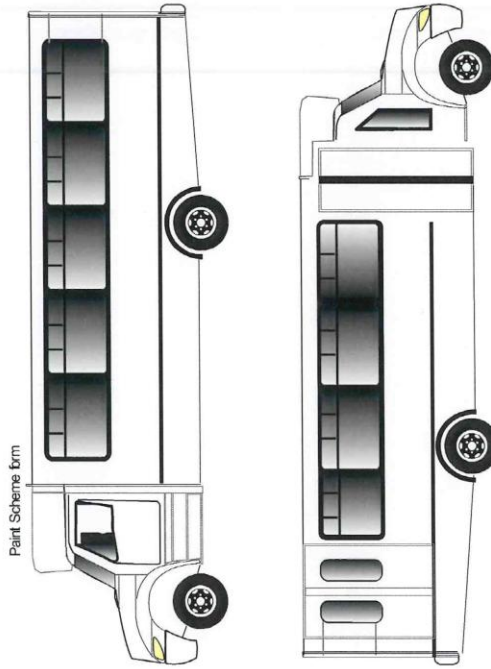

Sales:

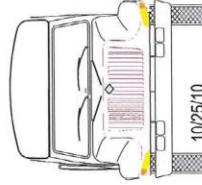
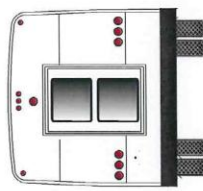

Vinyl Colors & Numbers

- 1.)
- 2.)

Paint Color Matched TTC

Robin Miller  
(Graphics Dept.)

Customer Signature

February 16, 06

Generic Form

# EXTERIOR PAINT SCHEME #2

Scheme 2 Belt Line Stripe

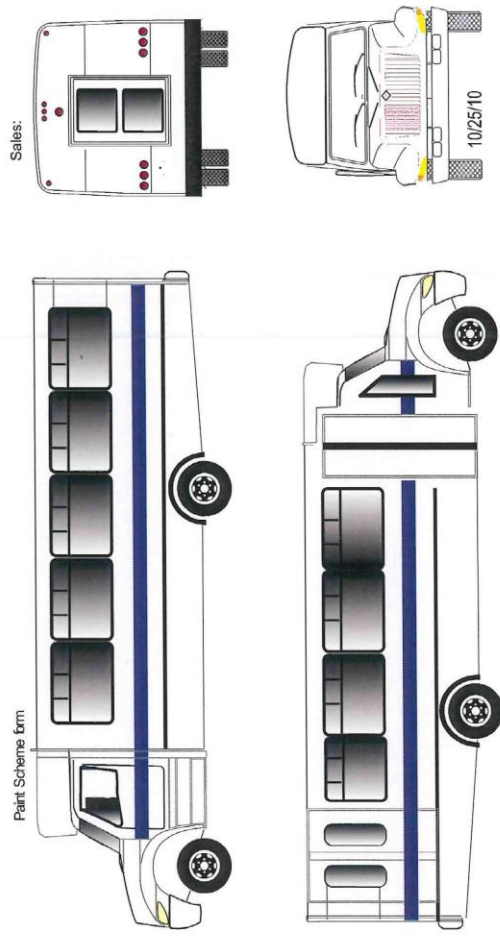

Paint Scheme DF 31' RL 217 WB yellow tyans

Sales:

Vinyl Colors & Numbers

- 1.)
- 2.)

Font from Midway ITC

Robin Miller  
(Graphics Dept.)

Customer Signature

Generic form

February 16, 06

# EXTERIOR PAINT SCHEME #3

Scheme 3 Skitch Paint

Paint Scheme DF 31' RL 217 MB yellow tyranis

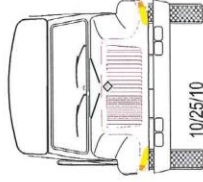
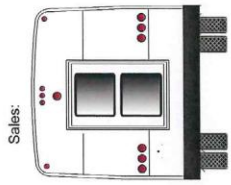
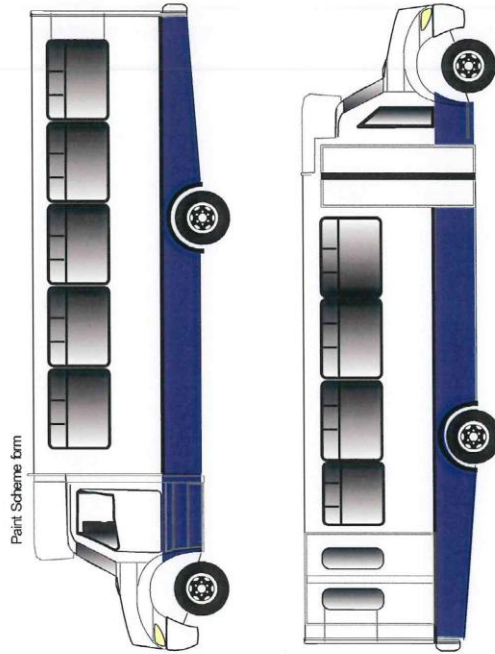

### Vinyl Colors & Numbers

- 1.)
- 2.)

Ford Econ Medium TTC

Customer Signature

Robin Miller  
(Graphics Dept.)

February 16, 06

# EXHIBIT E

## FLOOR PLAN LAYOUTS

Most agencies already have an idea on the type and number of seats and wheelchair positions needed to meet their floor plan requirements. A wide variety of alternative floor plans are available.

Agencies should work closely with Rivers Bus to develop and finalize their passenger seating floor layout plans. Based upon this consultation, Rivers Bus will develop a proposed floor plan based on the Agency's needs and fax a copy of the plan to the Agency for verification and approval.